

Description

The type CBD-01 Backdraught Damper has been designed to give maximum efficiency under arduous conditions and is suitable for fitting with the air flow in one direction only. The dampers may be installed vertically or horizontally with the air flow upwards.

Specification

Casing

The damper casing is formed from 3.0 mm thick sheet steel into a rigid channel section to ensure proper alignment of blades and shafts. Where circular dampers are required, additional spigot adaptors are used which increase the damper insertion length from 200 to 300 mm.

Blades

The blades are a formed single-skin of 1.5 mm sheet steel and seal against a flame retardant PVC strip attached to the blades and top and bottom stops.

Shafts

Continuous shafts \varnothing 9.5 mm.

Linkage

Parallel action linkage consisting of drive levers and bosses connected by flat bar link bars, driven through stainless steel pins. All linkage is contained within the depth of the casing.

Bearings

Phosphor bronze self lubricated 'Oilite' flanged bushes.

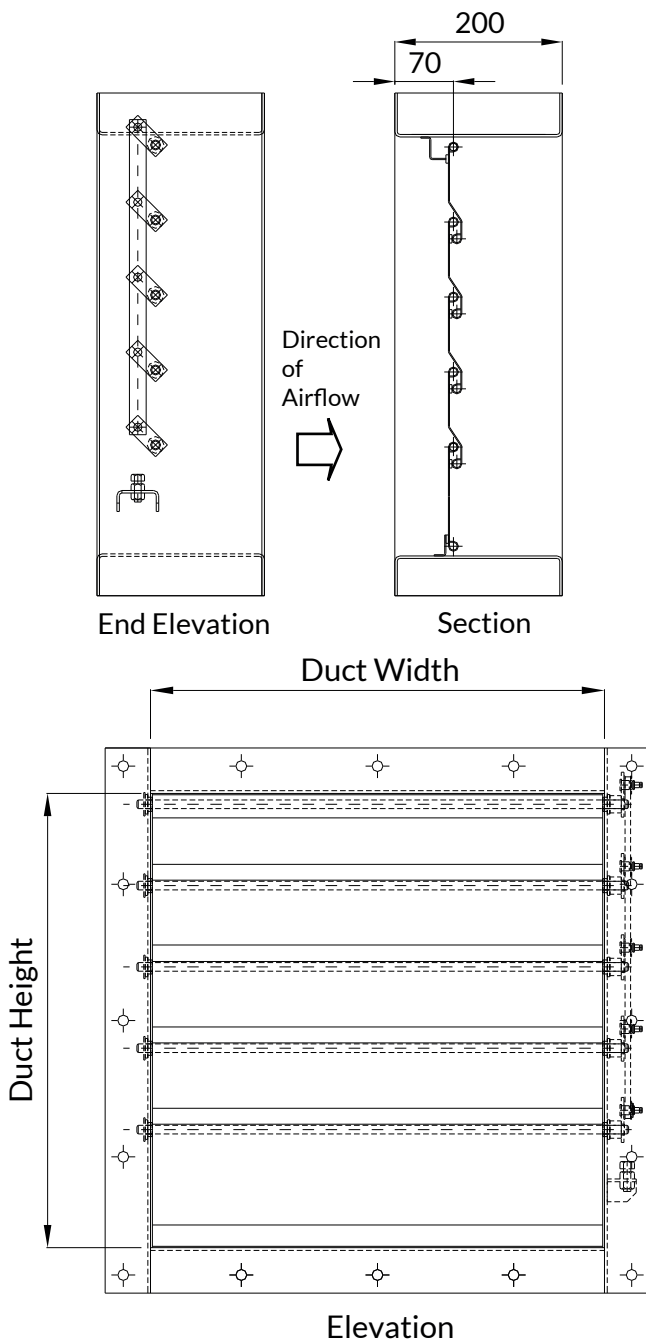

Options

- Materials can be stainless steel, galvanized mild steel or other materials to suit the clients' specific requirements.
- Earth continuity bosses.
- Lifting lugs.
- Flame retardant PVC blade seals.
- Integral or removable enclosures for housing control equipment.
- High temperature bearings.
- Shaft seals to provide airtight casings.
- Other variations to suit clients' specific requirements are also available.

Backdraught Damper

CBD-01

Installation & Assembly

An approved sealant should be inserted between the damper and duct flange to ensure a good seal.

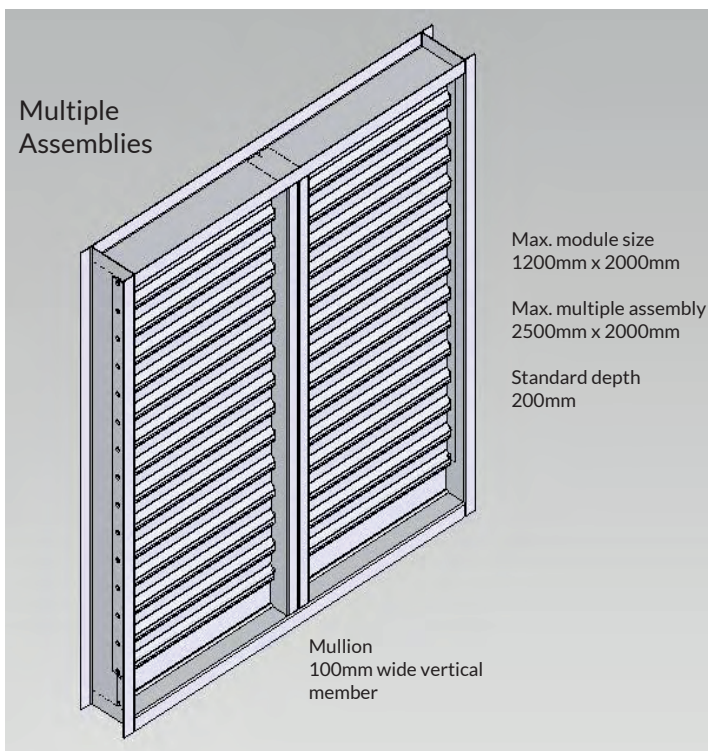
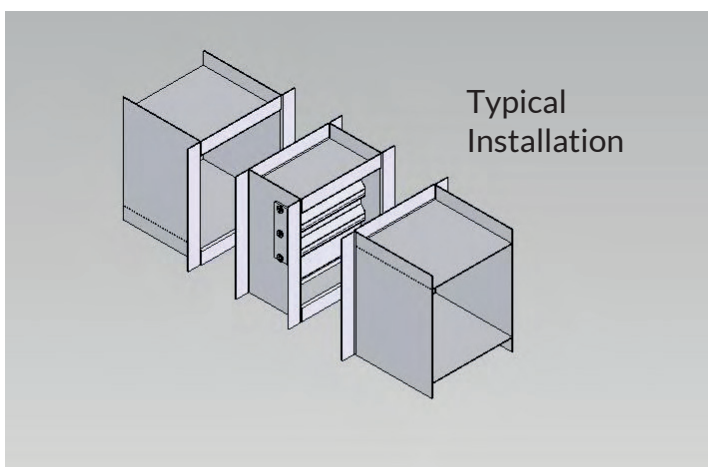

Leakage Characteristic Curve

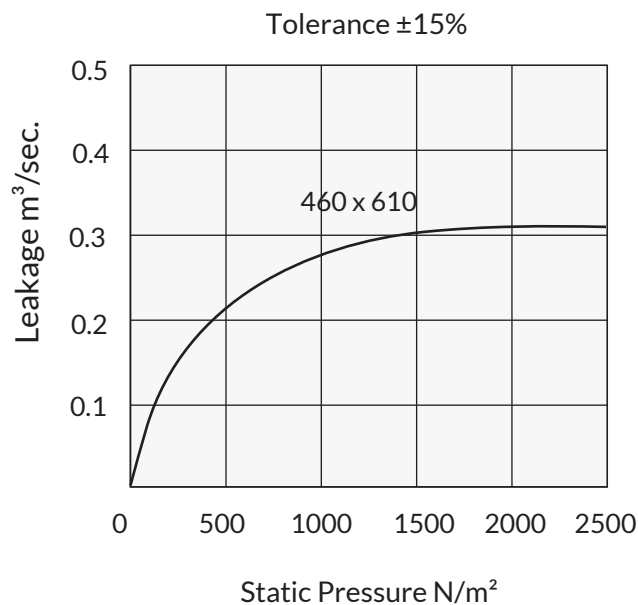

Open Pressure Drop Characteristic Curve

The static pressure drop curve - face velocity characteristic was conducted with free blades without spring or weight assistance or loading.

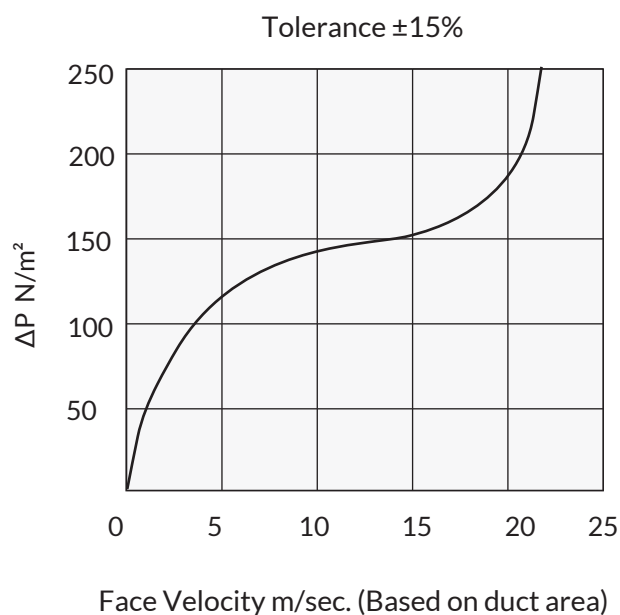

Flamgard-Calidair Engineering Limited,
Unit 2-4 Gemini Works, Estate Road,
Pontnewynydd, Pontypool, NP4 6YW,
Wales, United Kingdom

Tel: (+44) 01495 757 347
Fax: (+44) 01495 755 443

sales@flamgard.co.uk
www.flamgard.co.uk